

EMB-LR1121-e

Datasheet



Rev. 1.0

Embit s.r.l.

Document information

Versions & Revisions

Revision	Date	Author	Comments
1.0	2025-02-04	Embit	Initial release

PRELIMINARY

Index

1	Introduction	5
1.1	Specifications	6
1.2	Applications	6
2	Description	7
2.1	Block Diagram	7
2.2	STM32U0x	7
2.3	Transceiver	8
2.4	Antenna	8
2.5	Security Element	8
2.6	Crystals	9
2.7	Firmware	9
2.8	Development tools	9
3	Size and footprint	10
3.1	Size	10
3.2	Suggested footprint	11
3.3	Notes	12
4	Connections	13
4.1	Module pinout	13
4.2	Typical application circuit	15
5	Electrical characteristic	15
5.1	Absolute Maximum Ratings	15
5.2	Operating Conditions	15
5.3	Power Consumption	16
5.4	RF characteristics	16
6	References	17

7 Disclaimer of liability18
7.1 Disclaimer of liability 18
7.2 Handling Precautions 18
7.3 Limitations..... 18
7.4 Trademarks..... 18

PRELIMINARY

1 Introduction

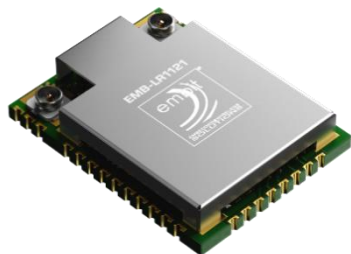

EMB-LR1121-e is the new ultra-low power subGHz and 2.4 GHz band-based OEM EMBit module. It exploits Semtech® proprietary spread spectrum modulation technique to provide long range connectivity and high-interference immunity, outperforming any other 2.4 GHz technology in terms of communication range. The radio is fully compliant with the worldwide

2.4 GHz frequency band regulation and can operate anywhere around the world. Also, the use of the 2.4 GHz ISM radio band, being not subject to duty cycle, allows to enhance the overall transmission rate with respect to others sub-GHz solutions.

EMB-LR1121-e is based on Semtech®'s LR1121 multi-band LoRa and Long Range 2.4 GHz transceiver coupled with the STM32U0x MCU. The MCU is equipped with up to 256 KB Flash memory and up to 40 KB of RAM memory. The module integrates three crystals, two at 32 kHz and one at 32 MHz and a Crypto Unit to protect the communication between the module and external interfaces, enhancing data security.

EMB-LR1121-e can communicate with other devices through a wide range of serial interfaces: UART, I2C, USB, SPI, several digital and analog I/O ports useful for the management of external devices and interfaces. Moreover, the extremely reduced low power consumption provided by the STM32U0x MCU, makes the **EMB-LR1121-e** particularly suitable to implement long life battery powered devices.

1.1 Specifications

EMB-LR1121	-e	-e/mesh	-e/b	-e/m
Operating Voltage:	1.8 ÷ 3.6 V			
MCU	Arm Cortex-M0+ 32-bit STM32U083		Arm Cortex-M0+ 32-bit STM32U031	-
RAM	40 KB		12 KB	-
FLASH size	256 KB		64 KB	-
Transceiver	Semtech® LR1121			
RF output power	up to 12 dBm			
RF sensitivity	down to -132 dBm at 595 bps			
Modulation:	LoRa® Spread Spectrum, FLRC, (G)FSK			
Operating Frequency:	868 MHz, 915 MHz and 2.4 GHz			
Frequency Range:	150 MHz to 960MHz (sub-GHz), 2400 MHz to 2485 MHz			
Interfaces:	UART/LPUART/I2C/SPI/ADC/GPIOs			
Dimensions:	15.5 x 20 x 2.3 mm			
Temperature Range	-40°C to +85°C			
	U.FL Connector or ceramic antenna			
	Crypto unit to protect communication			

1.2 Applications

The device can be used in several applications where LoRa® gateway is needed, such as:

- Internet of Things (IoT)
- Automated Meter reading
- Smart cities
- Home Building Automation
- Wireless Alarm and Security System
- Machine to Machine (M2M)
- Industrial Monitoring and Control
- Smart lighting

2 Description

2.1 Block Diagram

The **EMB-LR1121-e** block diagram is shown below:

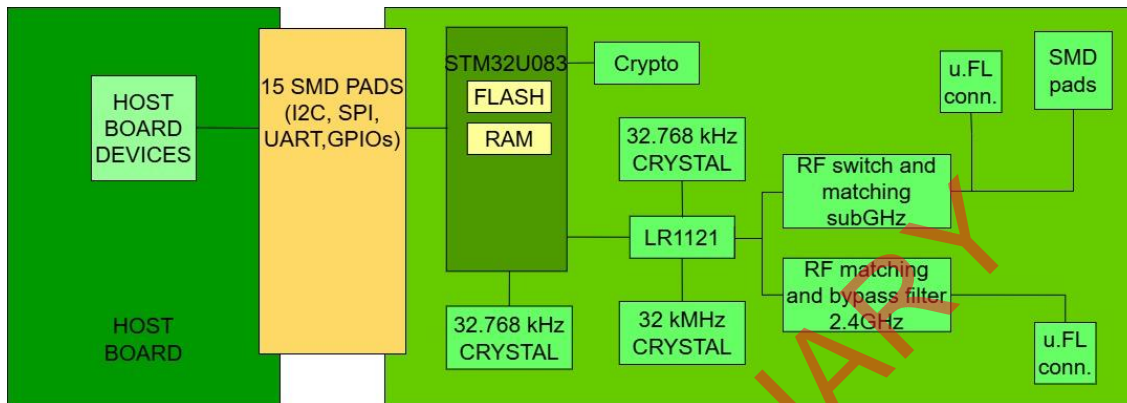

Figure 1 EMB-LR1121-e schematics

2.2 STM32U0x

The **EMB-LR1121-e** embeds an STM32U0x [1] MCU(*). It is an ultra-low-power, high-performance microcontroller based on an ARM Cortex M0+ 32-bit core operating at 32kHz. It is characterized by high-speed embedded memories (256 KBytes of data EEPROM, 40 KBytes of RAM for standard and /m version, instead 64 Kbytes of data EEPROM, 12 Kbytes of RAM for /b) and a Memory Protection Unit (**MPU**). The power management is highly effective and flexible thanks to the availability of 5 power modes, internal voltage adaptation and multiple internal/external clock sources. The MCU offers a wide range of standard and advanced interfaces such as I2C, SPI, USART and LPUART. Moreover, it embeds multiple analog and digital resources: 12-bit ADC with hardware oversampling, one RTC unit, multiple timers (with one low power timer), SysTick, programmable watchdog timer and multiple GPIOs.

(*Note: In **EMB-LR1121-e/b** version does not provide any STM MCU on board

2.3 Transceiver

The Semtech® **LR1121**[2] is a half-duplex transceiver that provides ultra-long range communication, high interference immunity with minimized current consumption in the subGHz and 2.4 GHz band.



Other than LoRa®, the **LR1121** supports

(G)FSK radio modulations. The maximum transmit power is 11.5 dBm at 2.4 GHz and 22 dBm at sub-GHz band with a receiver sensitivity of - 142 dBm @595 bps with LoRa® modulation @SF12 and 62.5KHz Bandwidth. The transceiver also offers a ranging engine with time-of-flight functionalities.

2.4 Antenna

The **EMB-LR1121-E** comes with two antenna options:

- 2 External antenna connector: 50 Ω single-ended U.FL connector
- For subGHz provide Ground-signal-Ground

2.5 Security Element

The **EMB-LR1121-E** features a crypto unit for protection, encryption and data security. This Security element is a high-security cryptographic device which combines world-class hardware-based key storage with hardware cryptographic accelerators to implement various authentication and encryption protocols.

It includes an EEPROM array which can be used for storage of up to 16 keys, certificates, miscellaneous read/write, secret data, and security configurations. Access to the various sections of memory can be restricted in a variety of ways and then the configuration can be locked to prevent changes.

It can be used as an Ecosystem control and Anti-Counterfeiting: it validates if a system or component is authentic and came from the OEM shown on the nameplate. The access to the device is made through a standard I2C interface at speeds of up to 1 Mb/s.

2.6 Crystals

The **EMB-LR1121-e** embeds two crystals:

- One 32MHz crystal required by the digital PLL of the transceiver to perform RF and baseband frequency conversion.
- One 32KHz crystal to be used as external clock source.
- Another 32KHz crystal connected to the MCU in standard and /b version. In /mesh version the 32KHz crystal is substituted with a TCXO

2.7 Firmware

The **EMB-LR1121-E** comes with Semtech[®] LoRaWAN[®] Modem-E stack.

2.8 Development tools

To work with **EMB-LR1121-e** the following tools are suggested:

- **STM32CUBEIDE**
- **ST-Link** debugger and programmer

Embit also provides ready-to-use firmware that allows the module to act as a simple modem over UART. This AT-like protocol is named "**EBI**" (**Embit Binary Interface**). By exploiting a set of binary commands, it is possible to configure the module, send/receive data over the air and develop complex applications without the need of writing complex custom firmware.

3 Size and footprint

3.1 Size

The mechanical dimensions of **EMB-LR1121-e** are 15.5 x 20 mm with a thickness of 3.2 mm (considering the shield).

The module has a total of 28 pins (10 on each side edge and 8 on bottom side) with 1.27 mm pitch and 1.02 x 0.81 as dimensions. Positioning is shown in the following image (Figure 2).

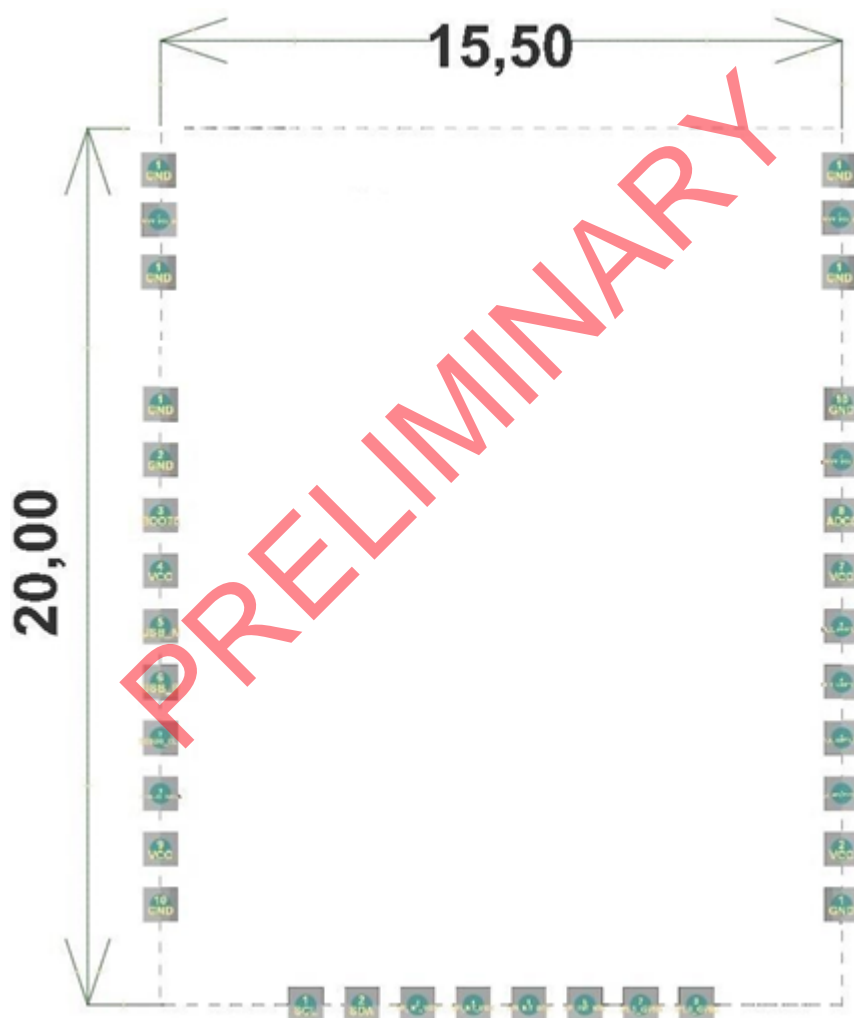

Figure 2 Connector positions

3.2 Suggested footprint

The **EMB-LR1121-e** suggested footprint consists in 28 LGA pads positioned as following (Figure 3 and Figure 4, all sizes are in mm).

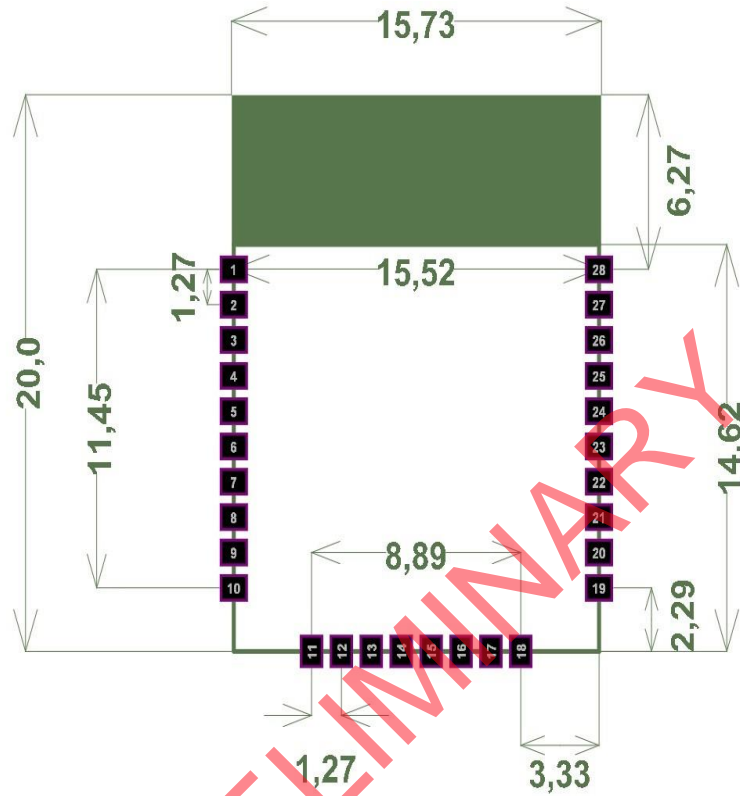

Figure 3 EMB-LR1121-e suggested footprint

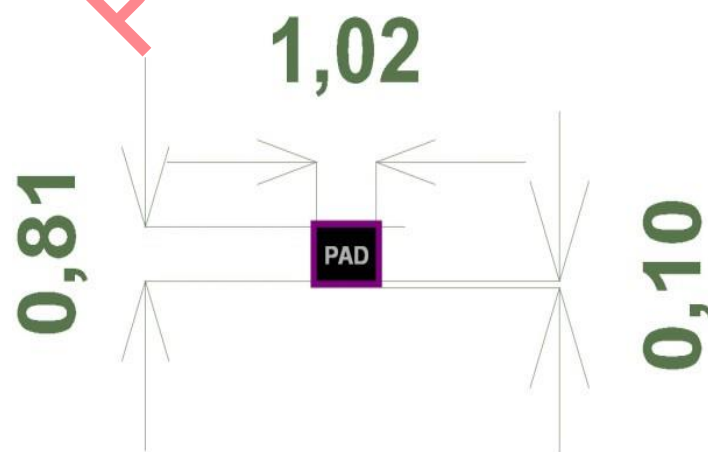

Figure 4 Pad

3.3 Notes

- The area underneath the module must be kept free of components (both top and bottom layers) and must be covered with solder resist.
- The PCB top layer underneath the module must be free of nets, power planes and vias.
- The module power supply must be as clean as possible. It must be decoupled placing a ceramic capacitor as near as possible to the Vcc pins. Additional filtering made by a ferrite bead is recommended.
- Noisy electronic components (such as switching power supply) must be placed as far as possible and adequately decoupled.
- The ground pins of the module shall be connected to a solid ground plane.

Note: Taking no account of these recommendations may affect the radio performances.

PRELIMINARY

4 Connections

4.1 Module pinout

EMB-LR1121-e, EMB-LR1121-e/b, EMB-LR1121-e/mesh			
Number	Pin Name	Type	Description
1	GND1	GND	Ground
2	GND2	GND	Ground
3	BOOT0	BOOT0 Input	BOOT0 pin
4	VCC	Power Input	Supply voltage
5	PA4	Digital I/O	I/O
6	PA3	Digital I/O	I/O
7	DEBUG_CLK	JTAG	SWD Debug port clock
8	DEBUG_DATA	JTAG	SWD Debug port data
9	VCC	Power Input	Supply voltage
10	GND3	GND	Ground
11	PB6_I2C_SCL	Digital I/O	I2C1 SCL
12	PB7_I2C_SDA	Digital I/O	I2C1 SDA
13	PA12_SPI_MOSI	Digital I/O	SPI MOSI
14	PA11_SPI_MISO	Digital I/O	SPI MISO
15	PA1_SPI_SCK	Digital I/O	SPI SCK, LPUART RX
16	PB10_SPI_NSS	Digital I/O	SPI NSS
17	LR_IRQ	IRQ Out	Radio IRQ*
18	PB0	Digital I/O	I/O
19	GND4	GND	Ground
20	VCC	Power Input	Supply voltage
21	PB1_UART_RTS	Digital I/O	UART RTS
22	PA6_UART_CTS	Digital I/O	UART CTS
23	PA5_UART_TX	Digital I/O	UART TX
24	PA7_UART_RX	Digital I/O	UART RX
25	VCC	Power Input	Supply voltage
26	PA0_ADC	Analog/Digital I/O	ADC_IN0
27	NRESET	Reset input	System reset input (active low)
28	GND5	GND	Ground
29	GND6	GND	Ground
30	RF_SIG	RF	RF sub-GHz input/output
31	GND7	GND	Ground

Table 1 EMB-LR1121-e Interface Pin Out, valid for standard /b and /mesh

EMB-LR1121-e/m			
Number	Pin Name	Type	Description
1	GND1	GND	Ground
2	GND2	GND	Ground
3	-	-	NC
4	VCC	Power Input	Supply voltage
5	-	-	NC
6	-	-	NC
7	-	-	NC
8	-	-	NC
9	VCC	Power Input	Supply voltage
10	GND3	GND	Ground
11	-	-	NC
12	-	-	NC
13	SPI_MOSI	Digital I/O	Radio SPI MOSI
14	SPI_MISO	Digital I/O	Radio SPI MISO
15	SPI_SCK	Digital I/O	Radio SPI SCK
16	SPI_NSS	Digital I/O	Radio SPI NSS
17	LR_IRQ	IRQ Out	Radio IRQ
18	PB0	Digital I/O	I/O
19	GND4	GND	Ground
20	VCC	Power Input	Supply voltage
21	BUSY	Digital I/O	Digital I/O
22	-	-	NC
23	-	-	NC
24	-	-	NC
25	VCC	Power Input	Supply voltage
26	-	-	NC
27	LR_NRESET	Reset input	Radio System reset input
28	GND5	GND	Ground
29	GND6	GND	Ground
30	RF_SIG	RF I/O	RF sub-GHz input/output
31	GND7	GND	Ground

Note: All Digital I/O support the MCU interrupt request.

*: IRQ pin of the radio. It is recommended not to connect anything to that pin in non /m version.

4.2 Typical application circuit

The external supply shall include protection from spikes, short circuits and it requires adequate decoupling.

- Voltage glitches on VCC supply may cause reset or malfunctioning of the microcontroller.
- Slow voltage ramp on VCC or NRESET may cause malfunctioning of the microcontroller.
- Do not reset or turn off the power of the module while writing to the flash; otherwise, memory corruption may occur.

5 Electrical characteristic

5.1 Absolute Maximum Ratings

Parameter	Value	Unit
Power Supply Voltage	+3.9	V
Voltage on any pin	+3.9	V
Rf input power (P_{max})	0	dBm
Storage Temp. Range	-40 ~ +85	°C

Table 2 Absolute Maximum Ratings

5.2 Operating Conditions

Parameter	Min	Max	Unit
Power Supply Voltage (Vcc)	+1.8	+3.6	V
Operating Temperature range	-40	+85	°C
Logic Input Low Voltage	Vss	0.3*Vcc	V
Logic Input High Voltage	0.7*Vcc	Vcc	V
Logic Output Low Level	Vss	Vss + 0.45	V
Logic Output High Level	Vcc-0.45	Vcc	V

Table 3 Operating Conditions

5.3 Power Consumption

Mode	Typ. value	Unit
Transmit @+11.5 dBm	28	mA
Transmit @+22 dBm	118	mA
Receive (2.4 GHz)	8.3	mA
Receive (sub-GHz)	7.8	mA
Sleep	2.5	μA
XLP Sleep	≤1	μA

Table 4 Power Consumption

5.4 RF characteristics

Condition	Min.	Typ.	Max.	Unit
RF Frequency range (sub-GHz)	150		928	MHz
Frequency tolerance		±10		ppm
Programmable Output Power Range (LPA)	-17		+14	dBm
Programmable Output Power Range (HPA)	-9		+22	dBm
RF Data Rate LoRa®	0.292		101.5	kbps
RX sensitivity SF7; BW=125 KHz		-118		dBm
RX sensitivity SF12; BW=125 KHz		-132.5		dBm
RX sensitivity SF7; BW=250 KHz		-116		dBm
RX sensitivity SF12; BW=250 KHz		-130		dBm
RX sensitivity SF7; BW=500 KHz		-112		dBm
RX sensitivity SF12; BW=500 KHz		-124.5		dBm

Table 5 RF characteristics sub-Ghz

Condition	Min.	Typ.	Max.	Unit
RF Frequency range (2.4 GHz)	2400		2485	MHz
Frequency tolerance		±10		ppm
Programmable Output Power Range (LPA)	-17		+14	dBm
Programmable Output Power Range (HPA)	-9		+22	dBm
RF Data Rate LoRa®	0.292		101.5	kbps
Rx sensitivity SF5; BW=406 KHz		-111		dBm
RX sensitivity SF7; BW=406 KHz		-129		dBm
RX sensitivity SF5; BW=812 KHz		-108		dBm
RX sensitivity SF7; BW=812 KHz		-112		dBm

Table 6 RF characteristics 2.4 GHz

6 References

- [1] STM, STM32U083KC Datasheet from www.st.com //
- [2] Semtech, LR1121 Datasheet from www.semtech.com //

7 Disclaimer of liability

The information provided in this and other documents associated to the product might contain technical inaccuracies as well as typing errors. Regulations might also vary in time. Updates to these documents are performed periodically and the information provided in these manuals might change without notice. The user is required to ensure that the documentation is updated and the information contained is valid. Embit reserves the right to change any of the technical/functional specifications as well as to discontinue manufacture or support of any of its products without any written announcement.

7.1 *Disclaimer of liability*

The user must read carefully all the documentation available before using the product. In particular, care must be taken in order to comply with the regulations (e.g., power limits, duty cycle limits, etc.).

7.2 *Handling Precautions*

This product is an ESD sensitive device. Handling precautions should be carefully observed.

7.3 *Limitations*

Every operation involving a modification on the internal components of the module will void the warranty.

7.4 *Trademarks*

Embit is a registered trademark owned by Embit s.r.l.

All other trademarks, registered trademarks and product names are the sole proprietary of their respective owners.